

<http://www.asiaequipments.com>

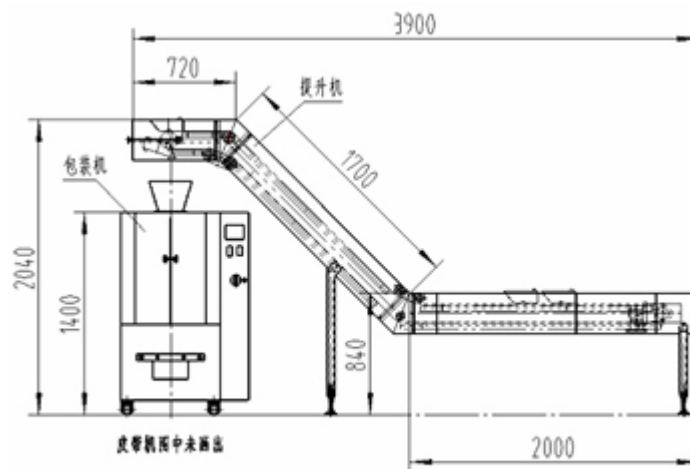

QP-398C Bucket Type Semi-Automatic Machine

Equipments:

1. 398 mainframe
2. manual material handling conveyor
3. Finished Products Conveyor

Features:

1. Manual measure and feed material
2. Easy to packing the tickets, awards, multiple materials due to the Bucket Type feeding.

3. Low cost and excellent performance

Application:

Widely used in the packing of the following listed bellows:

1. Crisp material: Potato chips, shrimp chips, etc.
2. Bulk Materials which can not be easy measured: Candy, jelly, bean sprout, tea leaf, dumpling, etc.
3. Small bags put in one large bag: medicine, food and commodity, etc.